

(c) Matthias Alles www-user.rhrk.uni-kl.de/~alles/fpga	
TITLE: Euterpe	
Document Number:	REV: A
Date: 3/28/2005 21:58:34	Sheet: 1/7

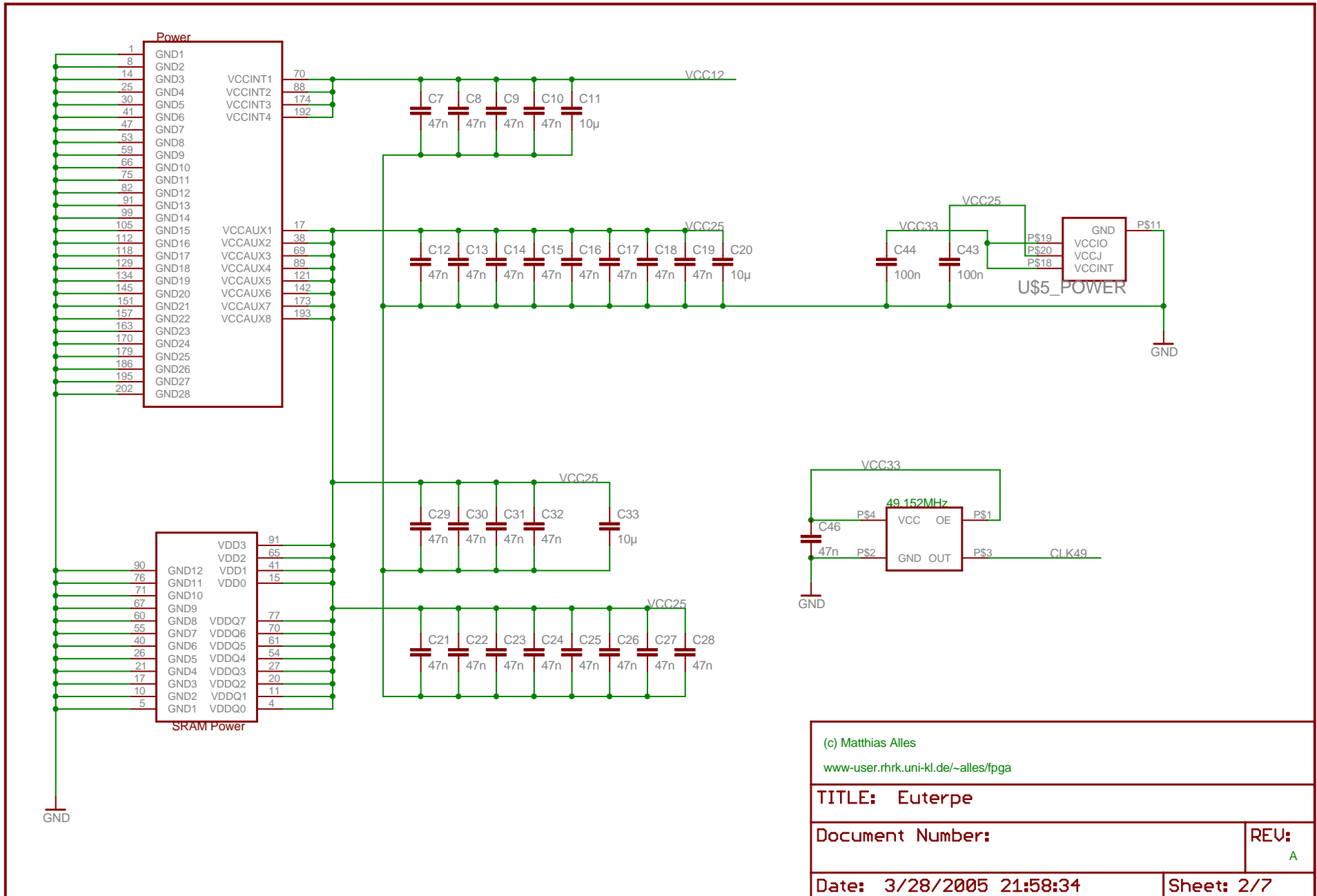

(c) Matthias Alles
www-user.rhrk.uni-kl.de/~alles/fpga

TITLE: Euterpe	
Document Number:	REV: A
Date: 3/28/2005 21:58:34	Sheet: 2/7

BANK 1		
VGA1_B4	161	L01P/VRN_1
VGA1_B3	162	L01N/VRP_1
VGA1_B2	165	L10P
VGA1_B1	166	L10N/VREF_1
VGA1_B0	167	IO_167
VGA1_G4	168	L27P
VGA1_G3	169	L27N
VGA1_G2	171	L28P
VGA1_G1	172	L28N
VGA1_G0	175	IO_175
VGA1_R4	176	L31P
VGA1_R3	178	L31N/VREF_1
VGA1_R2	180	L32P/GCLK4
VGA1_R1	181	L32N/GCLK5
VGA1_R0	182	IO_182

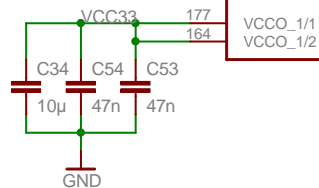

BANK 3		
BUTTON_2	131	L40N/VREF_3
BUTTON_1	130	L40P
LED_1	128	L39N
COD_LRCK	126	L39P
COD_BCK	125	L24N
COD_DIN	124	L24P
COD_DOUT1	123	L23N
COD_SCK1	122	L23P/VREF_3
COD_DOUT2	120	L22N
CAM_Y1	119	L22P
CAM_Y0	117	L21N
CAM_Y3	116	L21P
CAM_Y2	115	L20N
CAM_Y5	114	L20P
CAM_Y4	113	L19N
CAM_Y7	111	L19P
CAM_Y6	109	L17N
CAM_RST	108	L17P/VREF_3
CAM_FODD	107	L01N/VRP_3
I2C_SDA	106	L01P/VRN_3

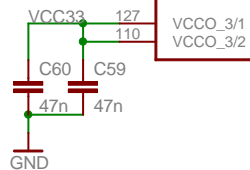

BANK 2		
VGA1_HS	156	L01N/VRP_2
VGA1_VS	155	L01P/VRN_2
VGA2_R0	154	IO_154/VREF_2
VGA2_R1	152	L19N
VGA2_R2	150	L19P
VGA2_G0	149	L20N
VGA2_G1	148	L20P
VGA2_G2	147	L21N
VGA2_B0	146	L21P
VGA2_B1	144	L22N
VGA2_B2	143	L22P
VGA2_HS	141	L23N/VREF_2
VGA2_VS	140	L23P
RS232_RXD	139	L24N
RS232_TXD	138	L24P
PS2_CLK1	137	L39N
PS2_DAT1	135	L39P
PS2_CLK2	133	L40N
PS2_DAT2	132	L40P/VREF_2

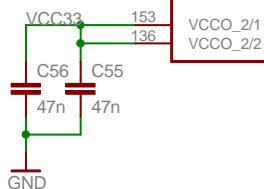

BANK 4		
CLK49	79	L32P/GCLK0
FLASH_CS	80	L32N/GCLK1
FLASH_SCK	81	L31P/DOUT/BUSY
CONF_INIT_B	83	L31N/INIT_B
FLASH_SI	85	IO_85/VREF_4
FLASH_SO	86	L30P
CAM_LUV6	87	L30N
CONF_RCLK	90	L27P
CAM_LUV7	93	L27N
CAM_LUV4	94	IO_93
CAM_LUV5	95	L25P
CAM_LUV3	96	L25N
CAM_PCLK	97	IO_96/VREF_4
CAM_VSYNC	100	IO_97
I2C_SCI	101	L01P/VRN_4
CAM_HREF	102	L01N/VRP_4
		IO_102/VREF_4

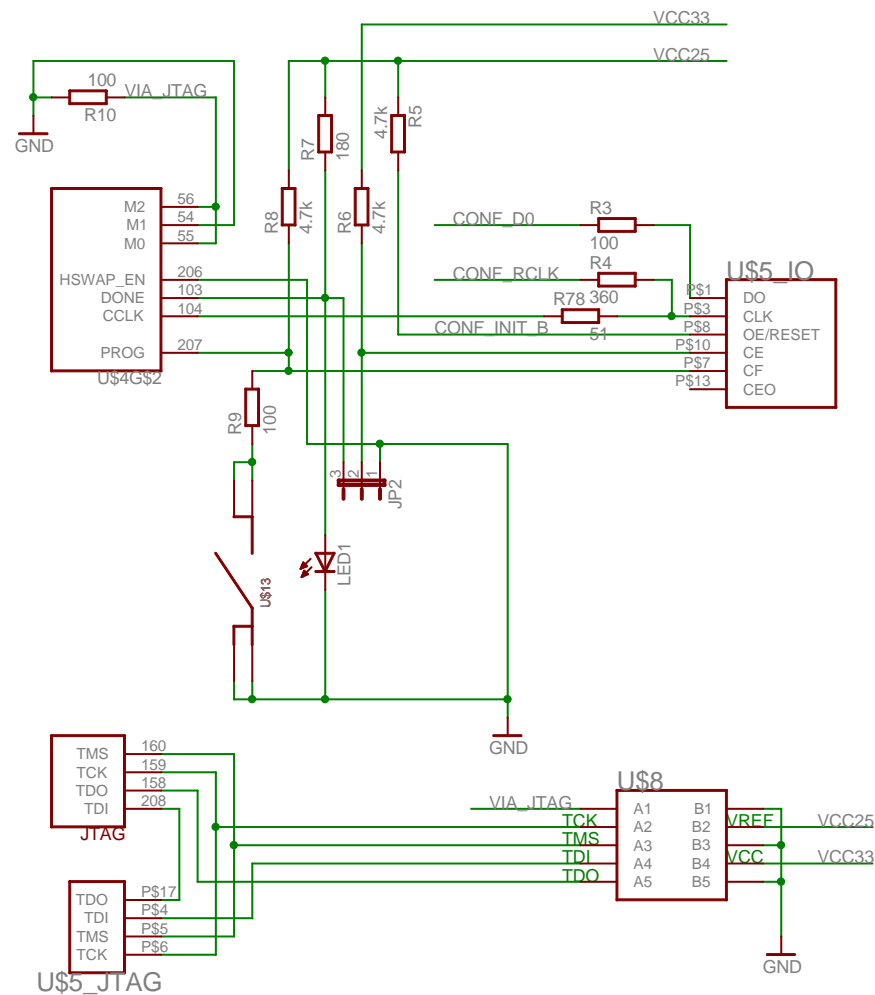
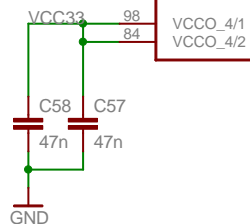

(c) Matthias Alles
www-user.rhrk.uni-kl.de/~alles/fpga

TITLE: Euterpe

Document Number:

REV:

A

Date: 3/28/2005 21:58:34

Sheet: 4/7

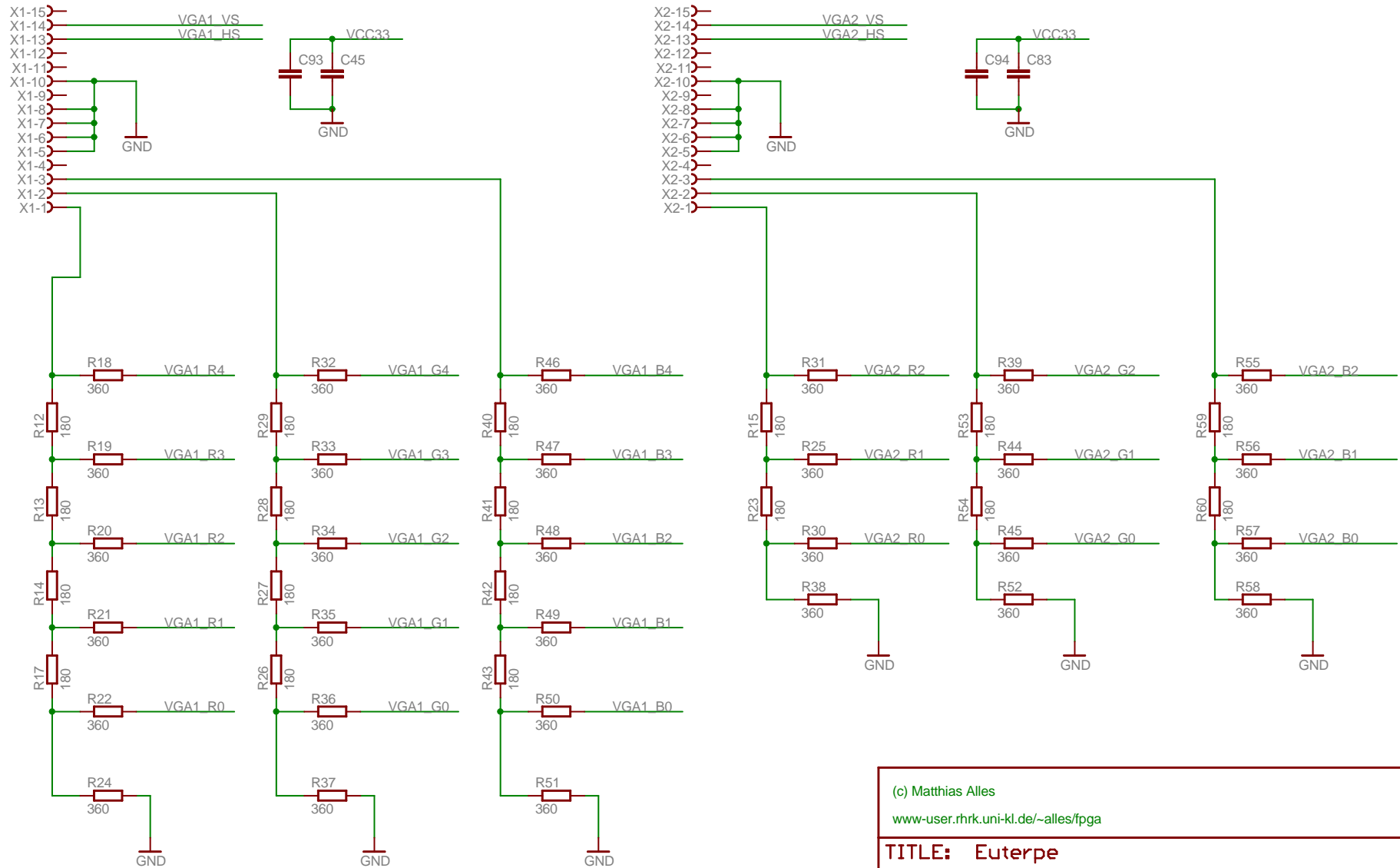

(c) Matthias Alles
www-user.rhrk.uni-kl.de/~alles/fpga

TITLE: Euterpe

Document Number:

REV:
A

Date: 3/28/2005 21:58:34

Sheet: 5/7

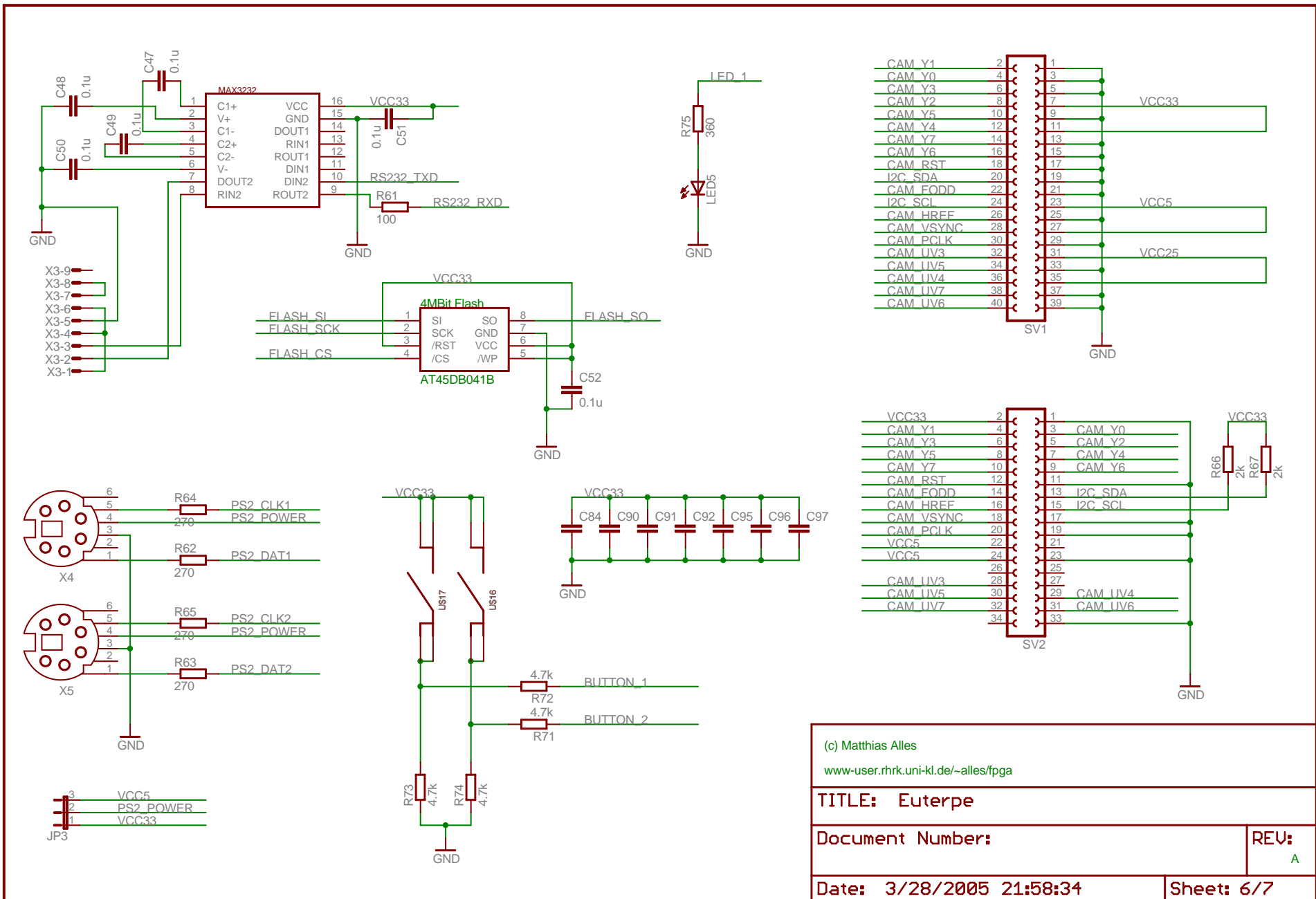

(c) Matthias Alles
www-user.rhrk.uni-kl.de/~alles/fpga

TITLE: Euterpe	
Document Number:	REV: A
Date: 3/28/2005 21:58:34	Sheet: 6/7

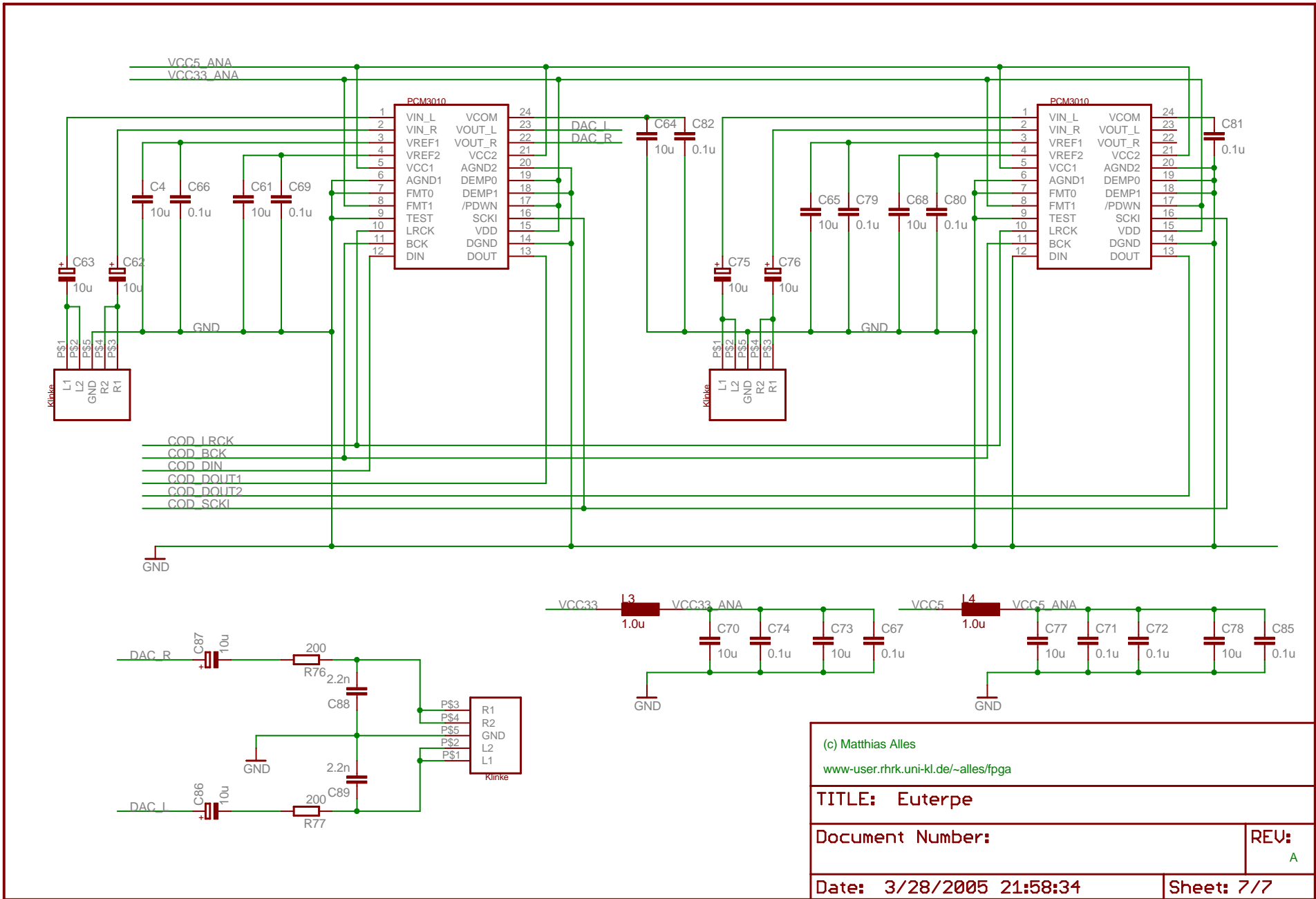

(c) Matthias Alles
www-user.rhrk.uni-kl.de/~alles/fpga

TITLE: Euterpe	
Document Number:	REV: A
Date: 3/28/2005 21:58:34	Sheet: 7/7